

CAVALLI

CMB-SO OPEN IMPELLER STAINLESS STEEL PUMP

The CMB-SO pump combines the advantages of open impeller with SUS 304 stainless steel construction, which is particularly suited for handling moderately aggressive liquids with suspended solids.

FEATURES

Liquids temperature: 90 °C (standard version)
Maximum pressure: 8 bar
Motor type: Standard IEC, Class F, IP 55
Voltage: 3/50/230~400V
Materials: SUS 304 wetted parts – Casing, Impeller, Shaft & back cover

APPLICATIONS

Industrial dish washer machines
Washing machines (washing vegetables, meats, fish)
Water treatment plants
Painting system cabins
Dyery machines
Ecology and food plants

DRAWING & DIMENSIONS

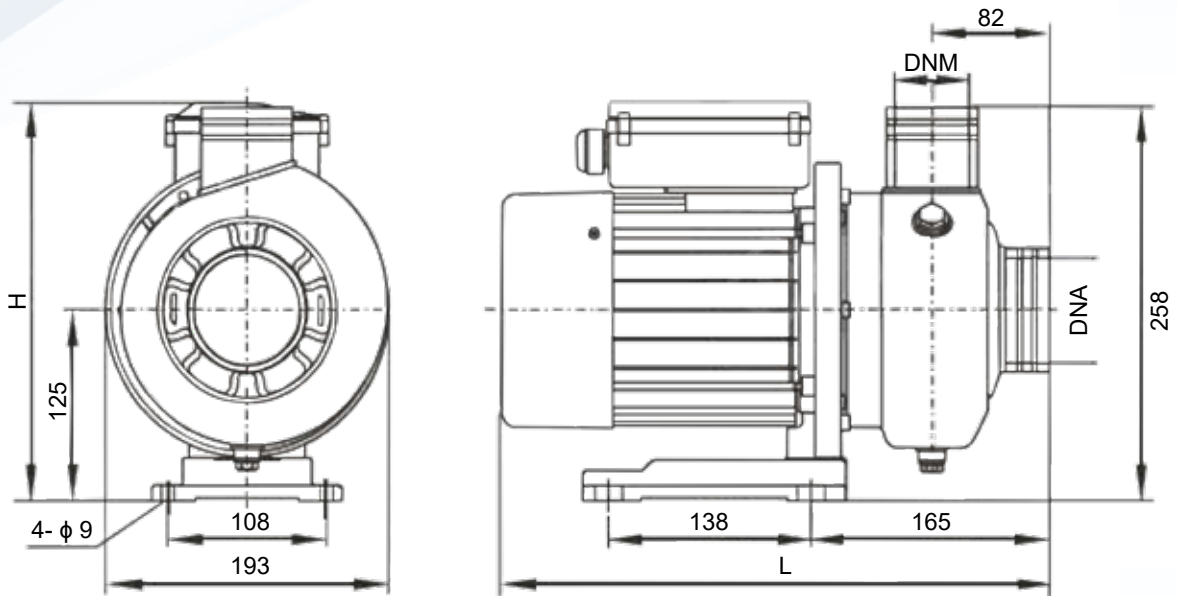

MODEL	POWER (P ₂) KW	AMPS	RATED HEAD (M)	RATED FLOW (M ³ /H)	L	H	DNA	DNM	WEIGHT (KG)	PACKING SIZE
CMB-SO 200	1.5	3.5	10.5	18	378	235	G2	G2	17.4	410 x 210 x 325
CMB-SO 300	2.2	4.9	11	30	415	242	G2½	G2	22	445 x 210 x 325
CMB-SO 400	3.0	6.3	15	30	432	242	G2½	G2	23	460 x 210 x 325

PERFORMANCE CURVES

